

GRID CONNECTED REDUCED SWITCH 7 LEVEL INVERTER BY MODEL PREDICTIVE CONTROL

S.SARADA ¹, C.GANESH ², K.KALPANA ³, R.GANGA BHAVANI ⁴,
Y.LAVA KUMAR ⁵, C.MAHESH ⁶

^{1,2}Assistant professor, Department of Electrical and Electronics Engineering, Annamacharya Institute of Technology and Sciences (AITS), Rajampet.

^{3,4,5}Student of Electrical Engineering, Annamacharya Institute of Technology and Sciences (AITS), Rajampet.

Abstract: Multilevel inverter's (MLI's) has been considered as the primary choice for most of the industrial applications because of its reliability and high power handling capability. In this paper, model predictive control has employed to guess the future values of load current by referring all the possible voltage vectors delivered by the inverter. Discrete-time model of the system is utilized to achieve the above mentioned function. The voltage vector by which the quality function is minimized, is selected. Then the usage of switch state deduced that obtained by the selected voltage vector is used to control the next output voltage of the inverter. This model is easy to implement and it has the ability to overcome the drawbacks of conventional control techniques that are applied to the MLI's. The result conveys that the model predictive control can effectively controls the load current and this system functions well.

Keywords – multilevel inverter; model predictive control; tracking performance

I. INTRODUCTION

Because of the vast usage of the fossil fuels, there is a sharp decrement in the availability of fossil fuel resources. To meet the day-to-day requirements of electricity, it's time to shift to the renewable energy sources. With the advancements in solar energy, the control techniques of grid connected inverters has been deploying from the few years. In order to obtain the above mentioned features, a multilevel inverter with minimum number of switches can be implemented to get a smooth sine wave. MLI's is widely used in high power applications such as large induction drive, UPS systems and FACTS systems.

Required output will be obtained from several level of dc links that are used in the circuit. Most commonly there are three different types of multilevel inverter topologies [1]-[2] used and they are Diode-clamped MLI's, Flying capacitor MLI's and Cascaded H-Bridge

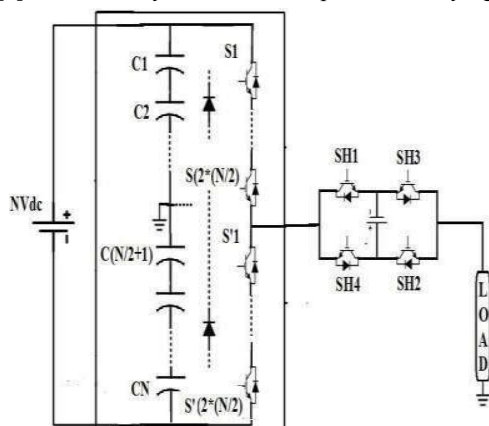

Fig1. Diode Clamped Multilevel Inverter DC-MLI

MLI's. Basically, three control techniques are available for controlling the grid connected multilevel inverters and those are Carrier wave comparison technique, Hysteresis loop control technique and predictive control technique. The widely used technique is the carrier wave comparison control, which tracks the output current by using a PI Controller [3]. But, it fails in reducing the steady-state error between the target current and the original current. The simplest control technique is the hysteresis loop control technique and it has the advantage of having good robustness [4]-[6], but it has high ripple content in the output current, which may increase the losses and thereby reducing the efficiency of the system. The another major

drawback is the unstable switching frequency. Model Predictive control is the main branch of Predictive control techniques. A model has to be established for the system in MPC [7]-[12]. Depending upon the designed model, the upcoming values of the variables can be predicted. Based on the comparison of the predicted values and the required reference values, the control action at this present moment will be taken. MPC structure is very simple for designing and modelling. Predictive control mode can be implemented on a digital signal processor and its output has small distortions in the current and harmonics are minimized.

II. DIODE CLAMPED MULTILEVEL INVERTERS

The most common multilevel architecture was introduced in 1975 and uses diode-clamped inverters. A diode serves as the clamping device in DC-MLI, which steps the output voltage by clamping the dc bus voltage. The primary concept behind the inverter is to employ diodes to minimize the voltage stress on the power electronic elements. A Vdc voltage is applied to each capacitor and switch. The number of shifting elements required are $2*(m-1)$, diodes are $(m-2)*(m-1)$, and voltage sources are necessary for a m level inverter (m-1). As the number of output voltage levels increase, the voltage waveform grows closer to a sinusoidal waveform and the output voltage quality improves.

III. SUGGESTED TOPOLOGY

A DC-MLI is a popular type of multilevel structure that uses diodes to clamp a component to the voltage of a dc bus to produce voltage steps in the output voltage waveform. The output voltage level determines the number of components required in all types of multilevel inverter.

Fig.1 proposed new single-phase topology

When more power switches are added to the inverter circuit, the price, control complexity, size, and the area for set up also increase. To provide a wide range of output levels while minimising the number of switches, the envisaged multilevel inverter employs an innovative power generating schematic diagram and an appropriate method to detect the level of the dc voltage source.

Figure 1 depicts the basic component of the recommended multilevel inverter.

The new configuration is as shown in Fig.1. The variety of different output voltage levels can be calculated by using the following equation. as in the shown MLI:

$$N_{Levels} = 2N + 3 \tag{1}$$

Where N is the number of voltage levels.

The following equation represents the single phase maximum output voltage (Vomax).

$$V_{0max} = \frac{(N+1)V_{dc}}{2} \tag{2}$$

In this new configuration, the below equations give the number of switches and diodes required,

$$N_{Switches} = 2N + 4 \tag{3}$$

$$N_{Clamping\ diodes} = N(N-1) \tag{4}$$

IV. MODULATION STRATEGY

Model Predictive control is the main branch of Predictive control techniques. A model has to be established for the system in MPC [7]-[12]. Depending upon the designed model, the upcoming values of the variables can be predicted. Based on the comparison of the predicted values and the required reference values, the control action at this present moment will be taken. MPC structure is very simple for designing and modelling. Adaptive control mode can be implemented on a digital signal processor, and its output has small deviations in current, reducing harmonics. It uses the toggle states deduced from the selected voltage vectors to control the next output values.

This control technique can be described as follows:

1. A model for the inverter output voltage vector has to be built.
2. A model for the load current has to be designed.
3. Quality function G has to be defined.

V. SIMULATION RESULTS

A model focused on the proposed architecture is simulated in order to confirm that the offered multilevel inverter produces an appropriate waveform of output voltage. Software called Matlab Simulink power blockset was used for the simulation. A seven-level staircase waveform with a frequency of 50 Hz is produced using the proposed multilevel in Figure 2. The following settings were used to test the filter in use: C = 10 f, L = 0.5 mH, and a load of 25 ohm.

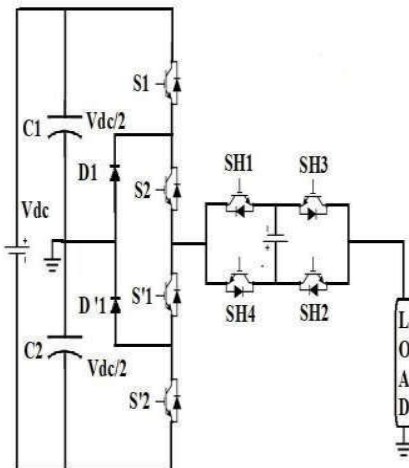

Fig2 Single-phase seven-level inverter

Table.1 Switching states of inverter

Switches	1.5 Vdc	1 Vdc	0.5 Vdc	0	-0.5 Vdc	-1 Vdc	-1.5 Vdc
s1	ON	ON	OFF	OFF	OFF	OFF	OFF
S2	ON	ON	ON	ON	ON	OFF	ON
S'1	OFF	OFF	ON	ON	ON	ON	ON
S'2	OFF	OFF	OFF	OFF	OFF	ON	OFF
SH1	ON	ON	ON	ON	OFF	OFF	OFF
SH2	ON	OFF	ON	OFF	OFF	ON	OFF
SH3	OFF	ON	OFF	ON	ON	OFF	ON
SH4	OFF	OFF	OFF	OFF	ON	ON	ON

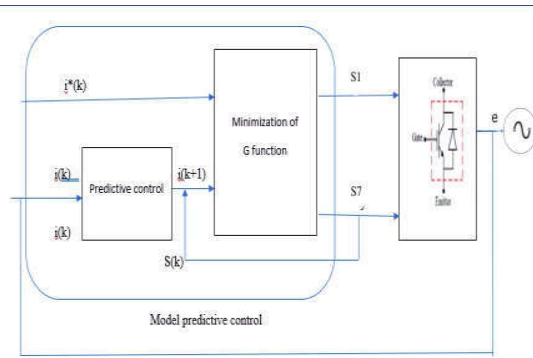

Fig.3 Schematic representation of Model predictive control

The model predictive control block diagram is shown in Figure 3. The following steps have to be followed for obtaining the model predictive control:

1. The measured value of load current is $i(k)$, and the reference value of load current is $i^*(k)$.
2. Model predictive control of load current is employed to calculate all possible output current values for future values.
3. A correlation must be carried out to identify the switching states with the smallest quality function values. Figure 4 shows the conventional simulation model of 7-level inverter, which has more number of switches

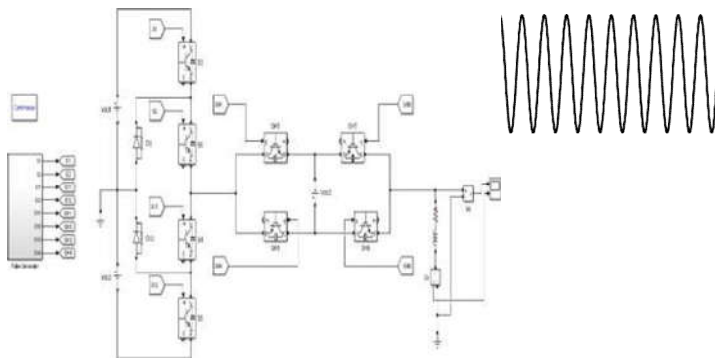

Fig.4 Conventional simulation model of 7-level inverter

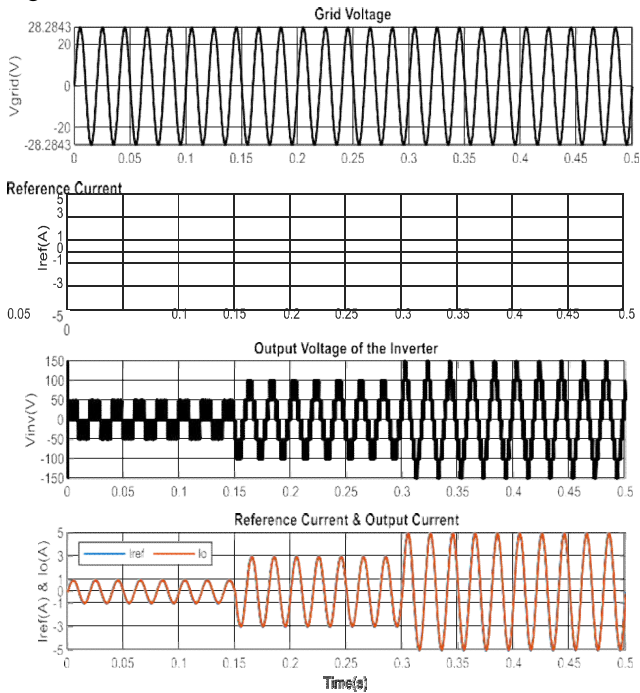

Fig.5 Output waveforms of proposed model by using MPC. With the model predictive control technique, desired output can be obtained as shown in fig.5 .

Figure 6,7 and 8 shows the total harmonic distortion of the load current.

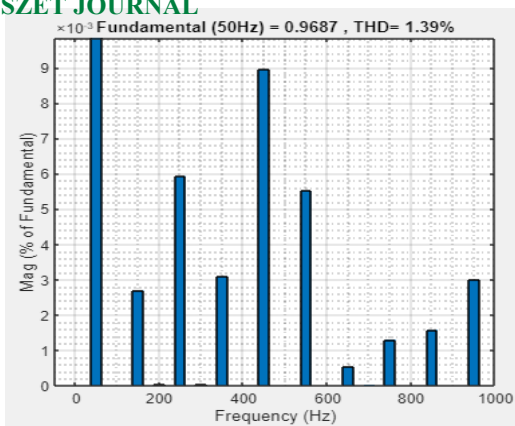

Fig.6 THD with $i^*(k)=1A$

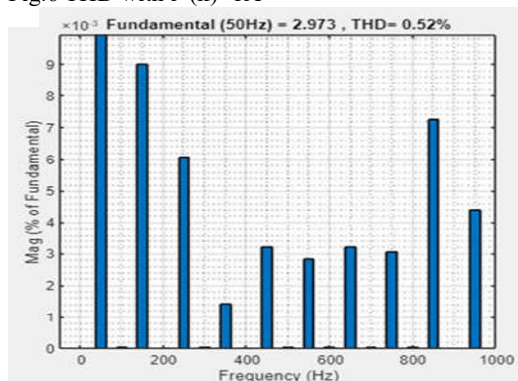

Fig.7 THD with $i^*(k)=3A$

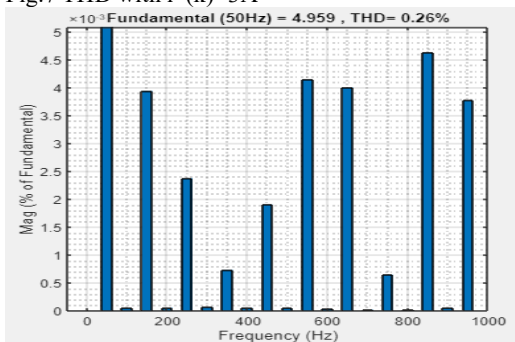

Fig.8 THD with $i^*(k)=5A$

From figures 6,7 and 8,the harmonic content will gets reduced with increase in reference current values.

V. Synopsis

This work proposes a novel multilevel inverter topology that require fewer switches. The multilevel inverter's action is clearly outlined. The proposed topology and recently disclosed topologies with three and four dc voltage sources were thoroughly compared. The topology was investigated using MATLAB/Simulink. The simulation results are also shown to demonstrate how effective the proposed model is. The FFT Analysis is advantageous to the paper because it has a lower Total Harmonic Distortion (THD) As a result, circuit complexity is reduced while system effectiveness is increased.

The recommended circuit would be very reliable and have minimal conduction losses due to its modest component count.

REFERENCES

- [1]. A. V. Singh and R. S. Singh, "A comparative study of multilevel inverter topologies," *Int. Res. J. Eng. Technol.*, vol. 5, no. 3, pp. 1009–1014, Mar. 2018.
- [2]. A. Salem, H. Van Khang, K. G. Robbersmyr, M. Norambuena and J. Rodriguez, "Voltage Source Multilevel Inverters With Reduced Device Count: Topological Review and Novel Comparative Factors", in *IEEE Transactions on Power Electronics*, vol. 36, no. 3, pp. 2720-2747, March 2021.
- [3]. C. Dhananjayulu, D. Prasad, S. Padmanaban, P. K. Maroti, J. B. Holm-Nielsen, and F. Blaabjerg, "Design and implementation of seventeenlevel inverter with reduced components," *IEEE Access*, vol. 9, pp. 16746-16760, 2021.
- [4]. Shukla, Anshuman & Ghosh, Abhijit & Joshi, Avinash. (2011). Hysteresis Modulation of Multilevel Inverters. *Power Electronics, IEEE Transactions on*. 26. 1396 - 1409. 10.1109/TPEL.2010.2082001.
- [5]. Rohith Balaji Jonnala, Ch Sai Babu, A Modified Multiband Hysteresis Controlled DTC of Induction Machine with 27-level asymmetrical CHB-MLI with NVC modulation, *Ain Shams Engineering Journal*, Volume 9, Issue 1, 2018, ISSN 2090-4479.
- [6]. International Conference on DESIGN AND MANUFACTURING 2013 (IConDM 2013) "Hysteresis Current Controller based Transformerless Split Inductor-NPC-MLI for Grid Connected PV- System" R.latha* , C.Bharatirajaa ,R.Palanisamyb,sudeepbanerjic, Dr.Subhransu.Sekhar.Dashd.
- [7]. Yang Zhao, Caiyong Ye, Yongzihao Dai, Kaifeng Liu, Sifeng Zhao, Cong Deng, "Research on Predictive Current Suspension Control of Permanent Magnet Bearingless Motor", 2021 IEEE 4th Student Conference on Electric Machines and Systems (SCEMS), pp.1-4, 2021.

- [8]. Nam Xuan Doan, Nho Van Nguyen, "Improved Model Predictive Control for Asymmetric Flying Capacitor 3-Level Inverter to Balance Capacitor Voltages and Reduce Computational Burden", 2022 25th International Conference on Electrical Machines and Systems (ICEMS), pp.1-6, 2022.
- [9]. Jean-Michel De Paris, Humberto Pinheiro, Fernanda de Moraes Carnielutti, Vinicius Foletto Montagner, Daniel Martins Lima, "MPC for Grid Forming Converters with Current Limiting", IECON 2022 – 48th Annual Conference of the IEEE Industrial Electronics Society, pp.1-5, 2022.
- [10]. Lin Peng, Lei Ma, Wensheng Song, Haoran Liu, "A Simple Model Predictive Instantaneous Current Control for Single-Phase PWM Converters in Stationary Reference Frame", IEEE Transactions on Power Electronics, vol.37, no.7, pp.7629-7639, 2022.
- [11]. Breno Vitorim Comarella, Lucas Frizera Encarnação, "Comparison of Model Predictive Control Strategies for Voltage Source Inverter with Output LC Filter", 2021 IEEE Southern Power Electronics Conference (SPEC), pp.1-6, 2021.
- [12]. MD SHAFIULLAH 1 , (Senior Member, IEEE), SHAKIR D. AHMED 1 , AND FAHAD A. AL-SULAIMAN," Grid Integration Challenges and Solution Strategies for Solar PV Systems: A Review", IEEE Transactions on Power Electronics, Vol.10, 2022.