

# EEG signal analysis based on Cascaded Optimized Adaptive filter

JayaLaxmi.Anem<sup>1</sup>, S. Roshini<sup>2</sup>, P. Sai Pooja<sup>2</sup>, K. Akhila<sup>2</sup>, M. Chandrasehkar<sup>2</sup>

<sup>1</sup>Sr. Assistant Professor, Department of Electronics and Communication Engineering, Aditya Institute of Technology And Management College, Tekkali, Srikakulam, Andhra Pradesh, India, 532201.

<sup>2</sup>Student, Department of Electronics and Communication Engineering, Aditya Institute of Technology And Management College, Tekkali, Srikakulam, Andhra Pradesh, India, 532201.

## **Abstract:**

*Electroencephalogram (EEG) plays an important role in identifying brain activity and behaviour. It is used to detect rhythms during sleep. Polysomnographic (PSG) is a test conducted to study sleep and to diagnose a variety of sleep disorders. It is a technique for sleep study. PSG records brain waves, oxygen levels in blood, heart rate (Electrocardiogram), breathing as well as eye movements (Electrooculogram) and muscle (Electromyogram) during the study. However, the recorded electrical activity always be contaminated with artifacts like Baseline, ECG, EOG, EMG and power line, and then affect the analysis of EEG signals. For this purpose, the cascade of Adaptive filters with LMS and Genetic algorithm are used to remove artifacts and extract the clean EEG signal, finding best coefficients of Adaptive LMS filter which minimizes the mean square error (MSE). We also measures the metrics like Signal to noise ratio (SNR), Mean Average Error (MAE), Least Mean Square Error (LSE) of proposed technique and compared with conventional techniques.*

**Keyword:** *Electroencephalogram, Adaptive filters, LMS and Genetic Algorithm*

## **1. INTRODUCTION:**

Electroencephalography (EEG) signals is used by physicians to analysis the signal in order to detect the rhythms during sleeping process and these signals are used widely for research purpose. EEG signal are mainly studied in polysomnography, based on that it can analyze the EEG signal. Polysomnography (PSG) is a test that is used to study the dynamic sleep and identify the sleeping disorders during one or more night in a laboratory. This electrical activity inside the brain can be caused by various actions such as movement of legs and arms, eye movement as well as spikes of heart problem solving and by imagination. Measuring electrical activity of the brain can be done using electrodes placed over the scalp. These electrical activities generally make some impure by combine with different noise and mixed with some other signal(biological) and call it as an artifacts that are power line interference, baseline interference, electrocardiogram (ECG), electrooculogram

(EOG) and electromiogram(EMG). EEG signal is used to detect the brain activities during sleep and the process will take both morning (who works at night) as well as in night time. The information related to brain activity and emotional states can be obtained through various consequences. It can provide specific information based on the person's abilities. EEG signals are frequently used for monitoring levels of alertness and mental engagement, investigating chronic conditions, and providing biofeedback or assistive devices. This process encompasses time, frequency, and spatial domains, offering a multi-dimensional approach to interpreting brain activities. By capturing complex neural patterns at high speeds, EEG signals offer a reliable, portable, and non-invasive method of measuring the electrical activity in the brain, thus allowing for the acquisition of valuable information. The electrical activity within the brain may stem from a range of activities, such as movements of the limbs, eye movement, problem solving,

heart spikes, and imagination. To measure this activity, electrodes are positioned on the scalp, and the resulting signal is known as an electroencephalogram (EEG). When a person moves their limbs, the EEG exhibits variations.

**2. Noises in EEG:**

While analyzing the EEG signal some artifacts are overlap and made disrupts between them and these artifacts are takes place in the signal like electrode position changes, electrode impedance, not clean the hair properly.

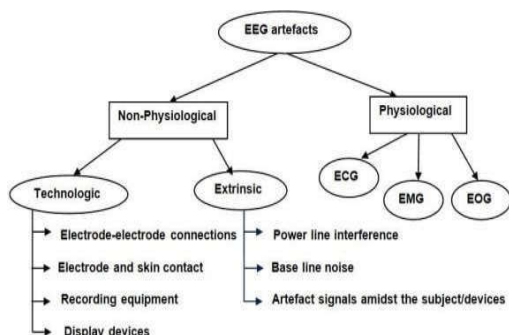

Fig 2: EEG Artifacts

**Power line interference:**

The power line interference represents a prevalent noise source in the ECG and other physiologic signals recorded from the body surface. The PLI is introduced because of the electromagnetic interference of the alternating power supply. Depending on the power supply, the frequency of PLI is 50 Hz or 60 Hz being the most.

**Baseline interference:**

Baseline interference is one of the major noise source in electrocardiogram and other physiological signal recorded from the entire body. The baseline artifacts are introduced by respiration and it have a very low- frequency, typically ranging from 0 to 0.7 Hz.

**ECG(Electrocardiogram):**

It is the process of producing an electric activity in the heart each time it beats. It is simplest and fastest test used to extract the signal from heart and the electrodes are placed at certain spots on the chest, arm and legs.

**EOG(Electrooculogram):**

EOG is the technique for measuring the cornea-retinal possibilities that are exists between the pairs of electrodes of the human eye.

**3. Extraction of EEG Signal:**

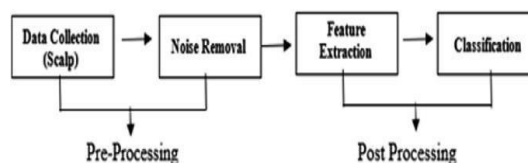

Fig 3: EEG Signal Processing

**Data collection:**

Here, it utilizes three distinct datasets to acquire signals, each of which has a varying number of electrodes. All of the datasets are here to the 10-20 electrode placement scheme, as shown. Dataset 1 records EEG signals from the scalp of 16 participants who are in a relaxed state with their eyes open, while dataset 2 records EEG signals from the scalp of 20 participants while they watch a movie. Finally, dataset 3 records EEG signals from 32 participants while they watch a music video. Our EEG signal collection is based on these datasets.

**Noise removal:**

All measurements are make impure by noise. It may be generated within the electrical components of the input. By generating a 100 Hz signal into an amplifier that covers 0 to 10 MHz by integrating the signal over a period, it will effectively reducing the bandwidth.

**Feature extraction:**

Feature extraction is the process of extract the raw data into some features that can be processed while preserving the information in the original dataset. It gives better results than applying some algorithm that are directly to the raw data. Feature extraction identifies the most discriminating characteristics in signal and we can easily consume the signal by using LMS and Genetic algorithm.

**Classification Algorithm:**

In this classification, LMS and Genetic algorithm with cascaded optimised adaptive filters to extract the clean EEG signals.

**1) LMS Algorithm:**

Least Mean Square (LMS) is an algorithm that is used in digital signal processing. It is a class of adaptive filter used to mimic a desired filter by finding the filter coefficient. By adjust the coefficients of a filter in order to reduce the mean square error between the desired signal and output of the filter.

$$w(n) = d(n) - p(n)$$

where,  $d(n)$  represents the desired signal and  $p(n)$  is the output of the filter. For weight vector, the equation is

$$w(n+1) = w(n) + 2 * a(n) * e(n)$$

where,  $a(n)$  represents the input of the filter,  $e(n)$  is the error signal,  $w(n)$  is the vector filter coefficient.

**2) Genetic Algorithm:**

Genetic Algorithm is a method for solving both constrained and unconstrained optimization problems that is based on natural selection. We can apply the genetic algorithm to solve a variety of optimization problems in which the objective function are discontinuous, non-differentiable, stochastic.

**4. Adaptive Filters:**

An adaptive filter possesses the ability to self-adjust its filter coefficients in order to conform to the input signal. This type of digital filter is commonly used in image processing to eliminate noise and play a significant role in noise cancellation, ANC, and equalization of common channels. Typically, adaptive filters function by overlapping the noise and signal, and a notch filter is employed to remove any interference between the two. These filters are primarily utilized in adjusting their coefficients to create an output

similar to artifacts present in EEG signals. The LMS algorithm is frequently used in the removal of noise from EEG signals since these adaptive filters widely employ it

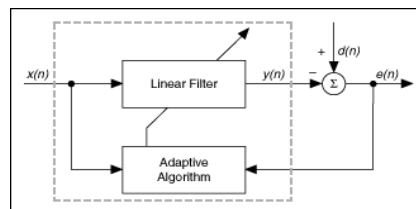

Fig 4: Structure of Adaptive filter

**5. Methodology:**

The implementation of this adaptive filters is used to remove noise in EEG signals, which are then studied by PSG. Because certain biological signals such as ECG, EOG, and EMG have overlapping spectra with EEG signals, conventional filters like band-pass, lower-pass, or high-pass filters cannot effectively remove these artifacts without also losing significant frequency components of the EEG signal. Therefore, it is necessary to design a specialized filter that can cancel out noise between artifacts or attenuate artifacts within the EEG signal.

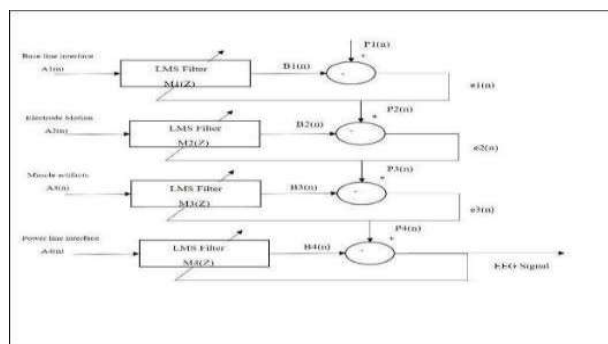

Fig 5: Block Diagram

Here, they developed an adaptive filter based on the LSM algorithm with genetic optimization. This method is particularly useful for filtering PSG recordings that contain ECG, EOG, and EEG signals.

**6. Result and Discussion:**

The results shows responses of the cascaded adaptive filter and compares the signal to noise ratio and noise parameters like LSE, MSE, MAE of EEG signal with LMS before and after using genetic algorithm.

**LMS Algorithm Waveform:**

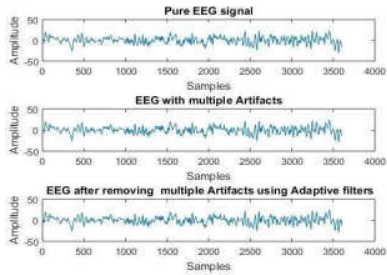

Fig 6.1: Waveform of LMS algorithm

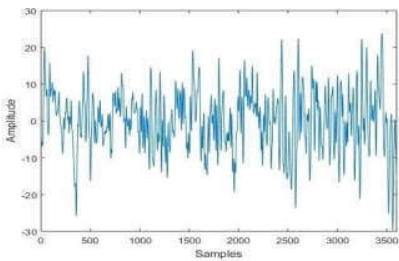

Fig 6.2: Pure EEG signal

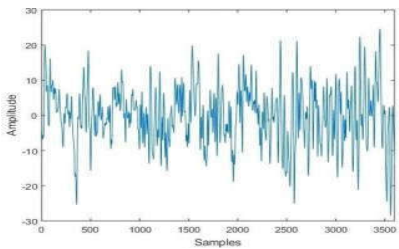

Fig 6.3: EEG signal with artifacts

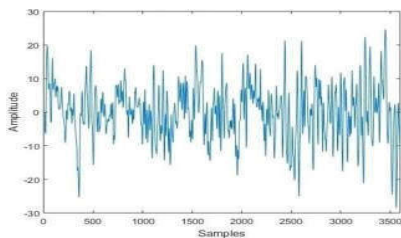

Fig 6.4: EEG after removing multiple artifacts using Adaptive filters

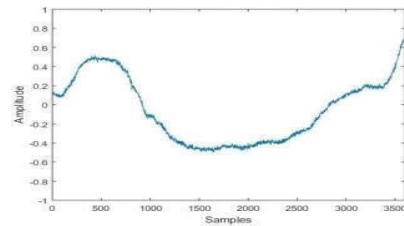

Fig 6.5 Baseline Artifacts

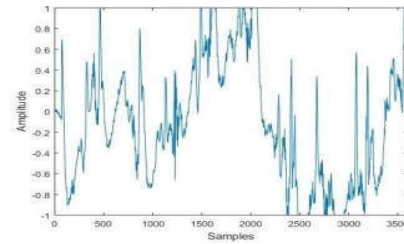

Fig 6.6: Electrode Motion artifacts

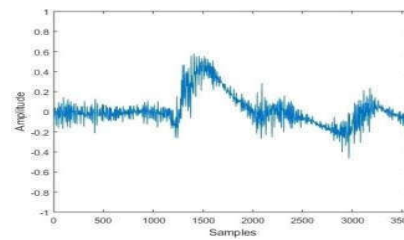

Fig 6.7: Muscle motion Artifacts

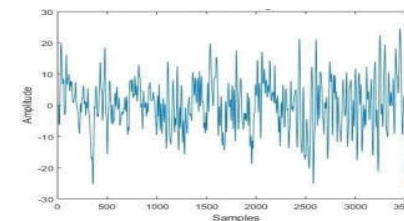

Fig 6.8: Noise EEG after removing baseline noise

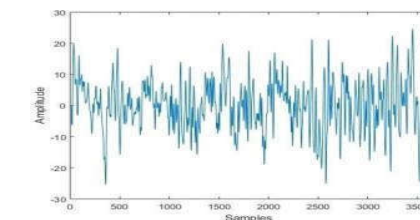

Fig 6.9: Noise EEG after removing baseline noise+ Electrode motion

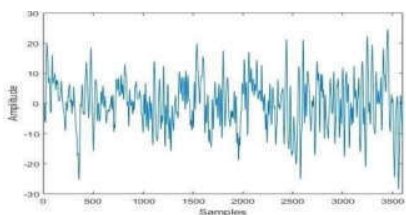

Fig 6.10: Noise EEG after removing baseline noise+ Electrode motion+ Muscle noise

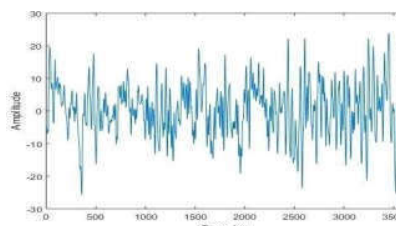

Fig 6.13: Pure EEG signal

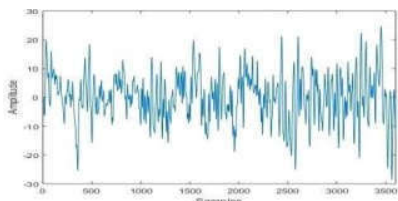

Fig 6.11: Pure EEG removing Artifacts

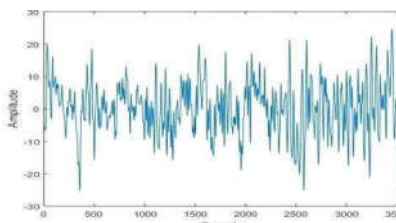

Fig 6.14: EEG signal with artifacts

**PARAMETERS OF LMS ALGORITHM WAVEFORMS:**

Step size	Input snr dB	Output snr dB	MSE	LSE	MAE
0.001	20.9097	93.1963	2.9780e-08	4.3506e-04	2.3945e-07
0.002	20.9097	86.8770	1.2231e-07	8.8114e-04	4.7515e-07
0.003	20.9097	83.1359	2.7824e-07	0.0013	6.9368e-07
0.004	20.9097	80.4351	4.9853e-07	0.0018	8.9128e-07
0.005	20.9097	78.2925	7.8615e-07	0.0023	1.0705e-06

Table 1: Parameter of LMS algorithm of Waveforms

From the table 1 it conclude that for the different step sizes can get different output SNR values and different error parameters like LSE , MSE , MAE. The output SNR decreases with increase in step size and Error also increases. So, 0.001 step size is the best step size.

**Genetic Algorithm with Wave form:**

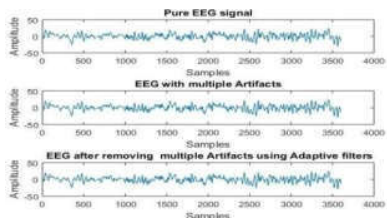

Fig 6.12: Waveform of Genetic algorithm

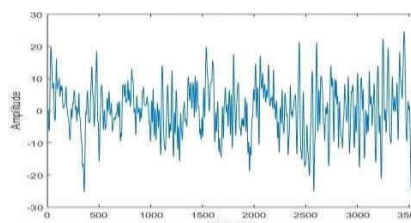

Fig 6.15 :EEG after removing multiple artifacts using Adaptive filters

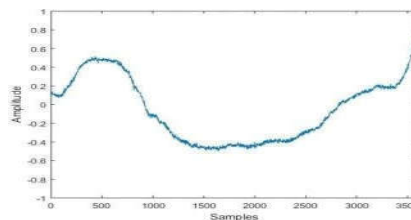

Fig 6.16 Baseline Artifacts

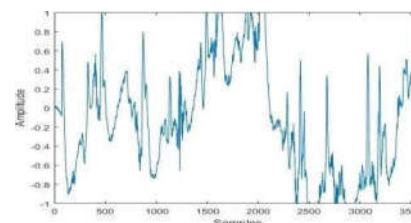

Fig 6.17: Electrode Motion artifacts

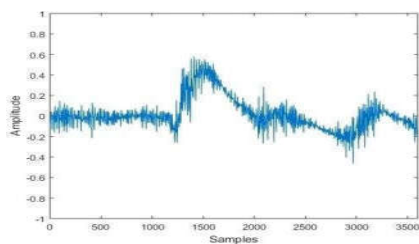

Fig 6.18: Muscle motion Artifacts

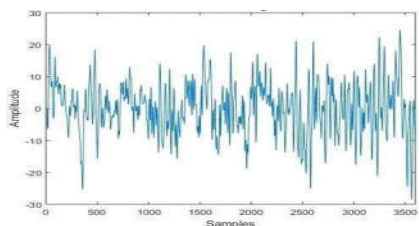

Fig 6.19: Noise EEG after removing baseline noise

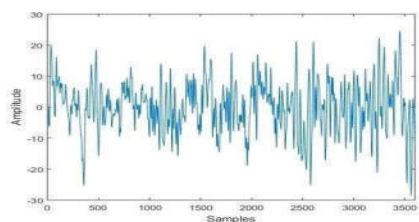

Fig 6.20: Noise EEG after removing baseline noise+ Electrode motion

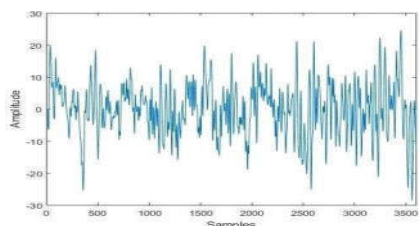

Fig 6.21: Noise EEG after removing baseline noise+ Electrode motion+ Muscle noise

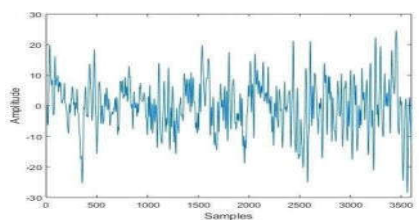

Fig 6.22: Pure EEG removing Artifacts

**PARAMETERS OF GENETIC ALGORITHM WAVEFORMS:**

Input snr db	Output snr db	MSE	LSE	MAE
20.9097	184.5040	2.2924e-17	1.2178e-08	4.7867e-12

Table:2 Parameter of Genetic Algorithm of waveforms

In LMS Algorithm, it can calculate the parameters of EEG signal based on different sizes and output SNR decreased. Here implemented the genetic algorithm for accuracy. We use one iteration value to get the result of best output SNR and Error.

**Conclusion:**

In this, the problem of noise canceller from EEG signal using Genetic Algorithm based LMS adaptive filters are proposed and tested on real signals with different artifacts obtained from MITBIH database. And genetic algorithm (GA) even gives better results form LMS algorithms which are presented in Table-2. From the simulation results it is clear that the adaptive filters combined with GA to removes non-stationary noise signals effectively which are shown interms of responses. Hence the proposed GA algorithm with LMS filters are more suitable for wireless biotelemetry EEG systems. Genetic algorithms can still achieve good results even in cases in which the function has several local minima or maxima.

**References:**

[1] Zou Y, Nathan V and Jafari R 2014 Automatic identification of artifact-related independent components for artifact removal in EEG recordings IEEE journal of biomedical and health informatics 20 73-81.  
 [2] Chen X, Peng H, Yu F and Wang K 2017 Independent vector analysis applied to remove muscle artifacts in EEG data IEEE Transactions on Instrumentation and Measurement 66 1770-9.  
 [3] Chen X, Liu A, Chen Q, Liu Y, Zou L and McKeown M J 2017 Simultaneous ocular and muscle artifact removal

from EEG data by exploiting diverse statistics Computers in biology and medicine 88 1-10.

[4] Somers B, Francart T and Bertrand A J J o n e 2018 A generic EEG artifact removal algorithm based on the multi-channel Wiener filter 15 036007.

[5] Huang, K.; Buzurovic, I.; Yu, Y. & Podder, T.K. (2010). A Comparative Study of a Novel AEnLMS Filter and Two Traditional Filters in Predicting Respiration Induced Motion.

[6] M. Rajya Lakshmi, T. Kameswara Rao, Dr. T. V. Prasad, "Exploration of Recent Advances in the Field of Brain Computer Interface", IOSR J. of Computer Engg., Vol.8, Issue 2, 2012.

[7] T. Kameswara Rao, M. Rajya Lakshmi, Dr. T. V. Prasad, "An Exploration of Brain Computer Interface and Its Recent Trends", Int. J. of Advanced Research in

Artificial Intelligence, Vol. 1, Issue 8, 2012.

[8] Jonathan R. Wolpaw, Niels Birbaumer, William J. Heetderks, Dennis J. McFarland, P. Hunter Peckham, Gerwin Schalk, Emanuel Donchin, Louis A. Quatrano, Charles J. Robinson, and Theresa.

[9] M. Vaughan, Brain-Computer Interface Technology: A Review of the First International Meeting, IEEE Trans. on Rehabilitation Engg, Vol. 8, No. 2,

[10] Senthilmurugan.M, Latha.M and Dr.Malmurugan.N, Classification in EEG- Based Brain Computer Interfaces Using Inverse Model, Int. J.of Computer Theory and Engg., Vol. 3, No. 2, April 2011.

#### About the Author:

Jayalaxmi Anem is currently working as a Sr. Assistant Professor in the Department of Electronics and Communication Engineering at Aditya Institute of Technology and Management, A.P., India. She had obtained her Bachelors Degree under AU, and M.Tech in VLSI System Design under JNTU, Kakinada. Her research areas of interest, includes Digital Signal Processing, Biomedical Signal, and Image processing.

